

- Improved properties
- Compatible to existing solutions

# 0.5 mm LL & CB Terminal System

0.5 mm **L**ocking  
**L**ance Terminal

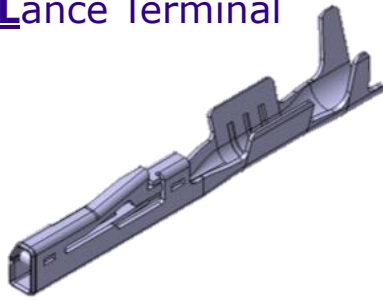

0.5 mm **C**lean  
**B**ody Terminal

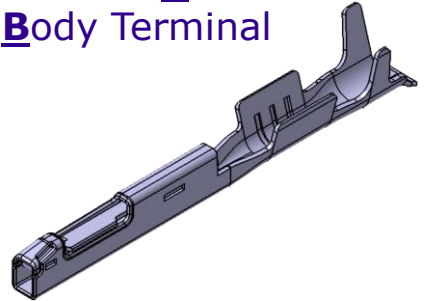

## Product description:



Compatible with the standard cavities



Compatible with Aluminum wire crimping



Low mating force

MicroFlex

Used for MicroFlex applications



Improved thermodynamic strength



Improved processability



Contact person for  
further information:

Mr. Andreas Brinkmann (SEWS-CE)  
[andreas.brinkmann@sews-ce.com](mailto:andreas.brinkmann@sews-ce.com)

- Verbesserte Eigenschaften
- Kompatibel zu bestehenden Lösungen

# 0,5 mm LL & CB Kontaktsystem

0,5 mm  
Kontakt mit  
Rastlanze (LL)

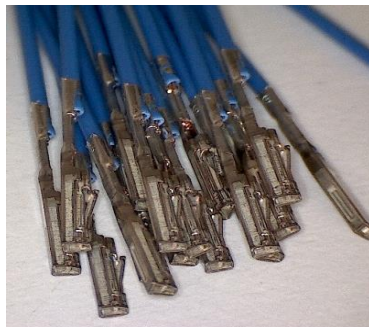
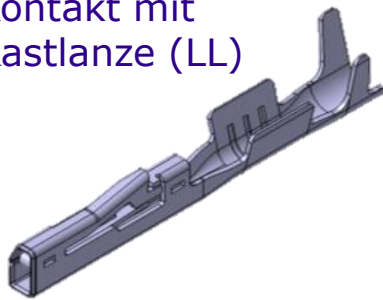

0,5 mm  
Kontakt ohne  
Rastlanze (CB)

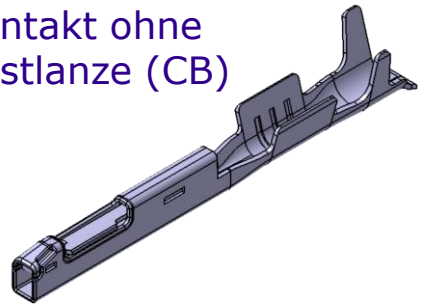

## Produktbeschreibung:



Kompatibel zur Standardkammer



Geeignet für den Einsatz  
mit Aluminiumleitung



Niedrige Steckkräfte

MicroFlex

Geeignet für MicroFlex-Anwendungen



Verbesserte thermo-dynamische  
Festigkeit



Verbesserte Verarbeitbarkeit



**Ansprechpartner für  
weitere Informationen:**

Hr. Andreas Brinkmann (SEWS-CE)  
[andreas.brinkmann@sews-ce.com](mailto:andreas.brinkmann@sews-ce.com)

- Improved properties
- Compatible to existing solutions

# 0.5 mm LL & CB Terminal System

0.5 mm **L**ocking  
**L**ance Terminal

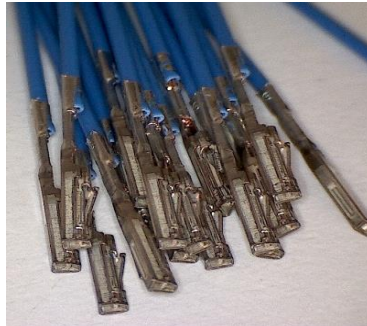
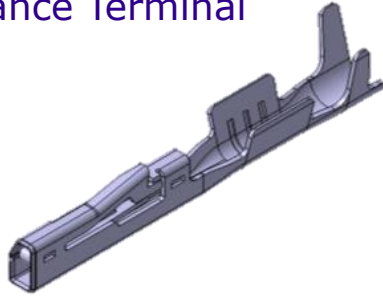

0.5 mm **C**lean  
**B**ody Terminal

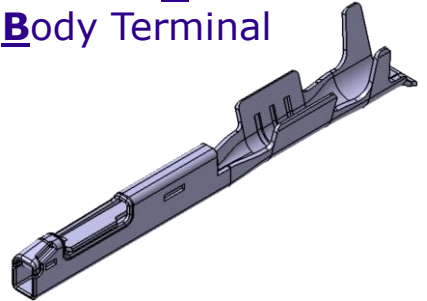

## Product description:



Compatible with the standard cavities



Compatible with Aluminum wire crimping



Low mating force

MicroFlex

Used for MicroFlex applications



Improved thermodynamic strength



Improved processability

## Contact person for further information:

Mr. Andreas Brinkmann (SEWS-CE)  
[andreas.brinkmann@sews-ce.com](mailto:andreas.brinkmann@sews-ce.com)

- Verbesserte Eigenschaften
- Kompatibel zu bestehenden Lösungen

# 0,5 mm LL & CB Kontaktsystem

0,5 mm  
Kontakt mit  
Rastlanze (LL)

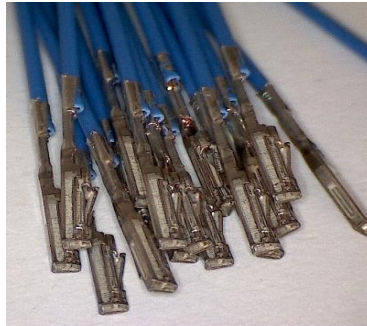
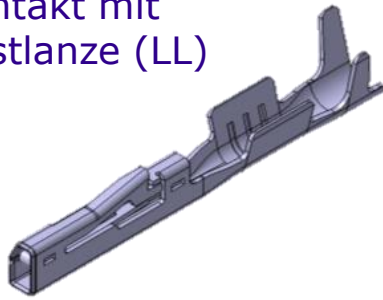

0,5 mm  
Kontakt ohne  
Rastlanze (CB)

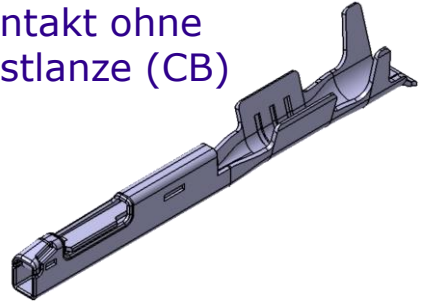

## Produktbeschreibung:



Kompatibel zur Standardkammer



Geeignet für den Einsatz  
mit Aluminiumleitung



Niedrige Steckkräfte

**MicroFlex**

Geeignet für MicroFlex-Anwendungen



Verbesserte thermo-dynamische  
Festigkeit



Verbesserte Verarbeitbarkeit

## Ansprechpartner für weitere Informationen:

Hr. Andreas Brinkmann (SEWS-CE)  
[andreas.brinkmann@sews-ce.com](mailto:andreas.brinkmann@sews-ce.com)